

H
JACKS



CAPACITY

2.5 - 25 ton

STROKE

110 - 150 mm

THE **DTJ-SERIES** TOE JACKS ARE A PREMIUM RANGE IDEALLY SUITED TO LIFTING HEAVY MACHINERY OR EQUIPMENT WHEN ACCESS HEIGHT IS RESTRICTED.

Toe lift capacities range from 2.5-25 ton and all models feature a keyed toe with spring return piston.

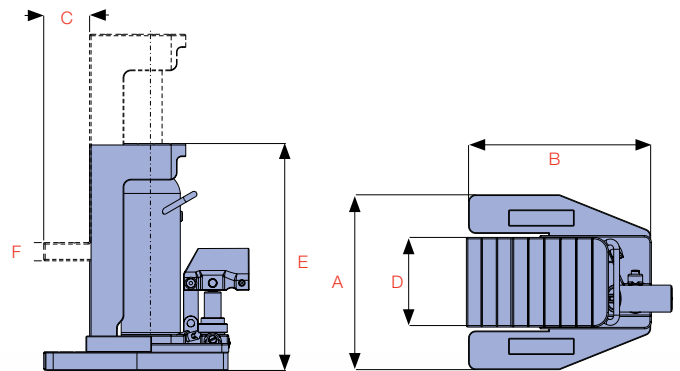

CHROME PLATED

steel piston rod resists corrosion and extends life

DOVETAIL DESIGN

for perfect alignment of toe during lift (25 ton jack does not have dove tail design)

EASE OF USE

all jacks have been designed for ease of use and handling

CARBON STEEL BASE

is welded to ensure increased resistance to high pressure and provide greater durability

OPERATING HANDLE

included with all models

360° ROTATING

pump handle on models 2.5-15 ton

INTERNAL STROKE LIMITER

prevents piston rod over-extension

LIFTING TOE

manufactured from high strength alloy steel

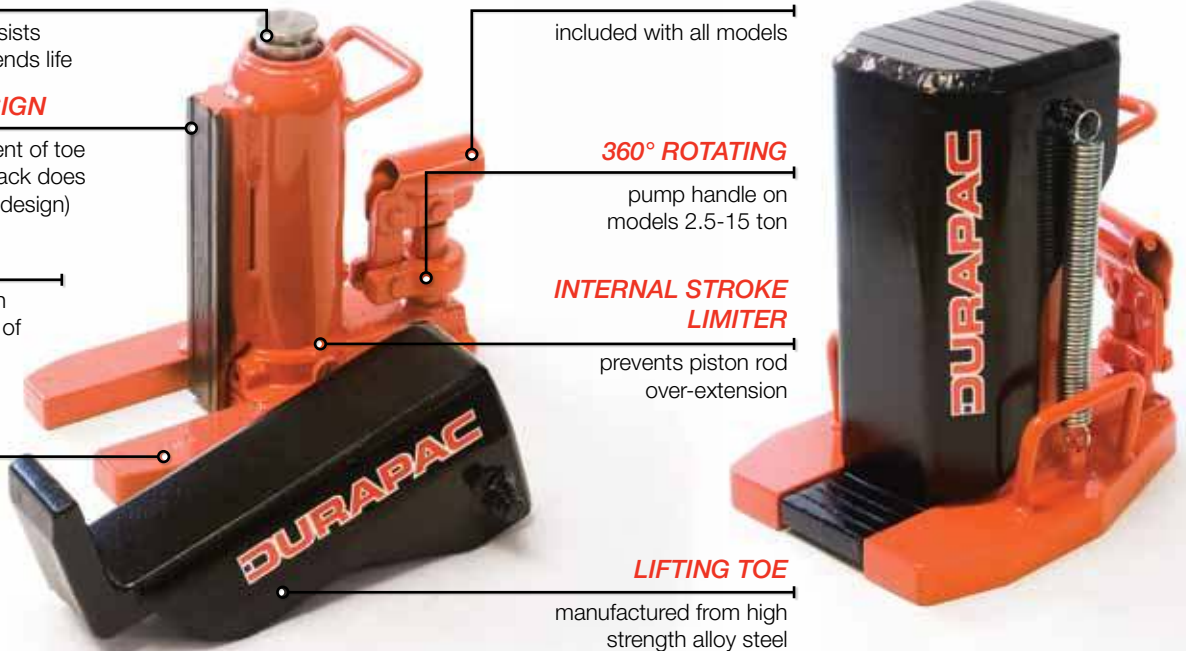

Model No.	Jack Capacity ton* / kN	A Jack Width (mm)	B Jack Depth (mm)	C Toe Length (mm)	D Toe Width (mm)	E Collapsed Height (mm)	F Min. Toe Height (mm)	Stroke (mm)	Weight (kg)
DTJ-2.5	2.5 / 24.5	126	233	60	50	232	19	110	11.6
DTJ-5	5 / 49.0	182	259	60	75	282	22	130	22.0
DTJ-10	10 / 98.0	215	275	63	85	320	28	140	32.0
DTJ-15	15 / 147.0	238	297	60	85	328	30	140	42.0
DTJ-25	25 / 245.1	320	368	60	125	364	34	150	100.0

* Nominal Jack Capacity in ton - see kN values for actual capacity