

# bomaq

## B30 MP 4WD



### KEY FEATURES

- UNIQUE STEERING SYSTEM
- 4WD HYDROSTATIC TRANSMISSION
- OPEN / ENCLOSED AIR-CONDITIONED CABIN
- COMPACT SIZE
- HIGH QUALITY COMPONENTS
- ROBUST AND RELIABLE
- EASY MAINTENANCE
- INCOMPARABLE VERSATILITY

**NIMAC**  
PACIFIC

# B30 MP 4WD

B30MP		DIMENSION	
H6*		1990mm (AU)	
X		655mm	
Y		1975mm	
L2		3130mm	
M2		250mm	
B1		1500mm	

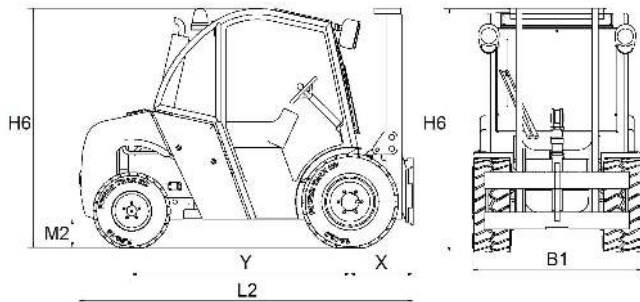

\*h6 indicates a standard unit equipped with a Triplex 3.3 mast

## PERFORMANCE

MODEL	B30MP
Unladen Weight**	4560Kg
Maximum Load Capacity (Load center 500mm)	3000Kg
Maximum Load Capacity (load center 600mm)	2750kg
Capacity at maximum height (load center 500mm)	2600Kg
Capacity at maximum height (load center 600mm)	2390Kg
Maximum Lift height (Standard Triplex /Free lift mast)	3300mm
Turning Radius	2690mm
MAX Speed	24 Km/h
MAX Slope with load	30%
MAX Slope without load	40%

\*\* Indicated weight can vary, depending on the machine configuration

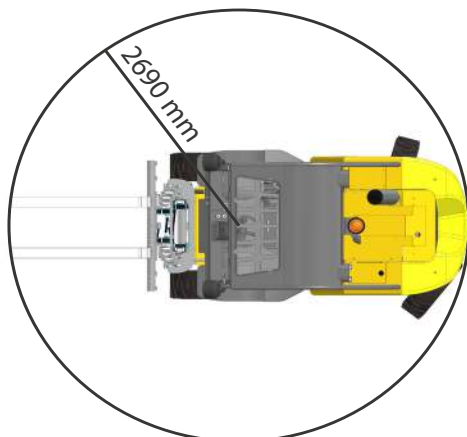
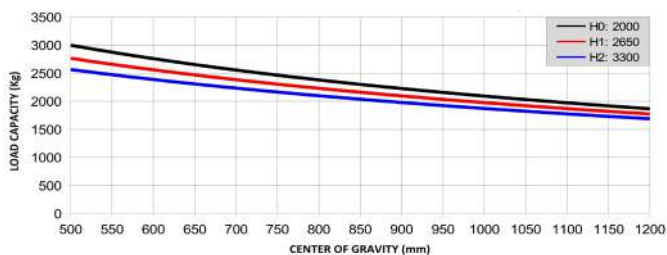

## STANDARD SPECIFICATIONS:

ENGINE	
Model	Perkins 404D-22 Tier3A
Engine Power	(36,3Kw/48,7Hp)

TRANSMISSION	
Type/Model	Hydrostatic 4WD LINDE transmission
Front Axle	ZF with Limited Slip Differential
Rear Axle	BOMAG Steering axle with Hydrostatic Drive motors
Maximum Speed	24Km/h
Permanent 4wd, 2 Speed transmission	Std
Inching Control on Brake Pedal and Joystick	Std

BRAKES	
Service Brakes	Multidisc hydraulic service brakes on front axle
Parking Brake	Multidisc hydraulic parking brake with automatic activation

TYRES	
Front Standard Tyres	MPT All terrain 12x16.5
Rear Standard Tyres	MPT All terrain 27x8.50 - 15

CABIN	
Open cabin Structure FOPS and ROPS approved	Std
Double hydraulic joysticks with integrated reverse shuttle	Std
Front laminated Windscreen	Std
Rear laminated glass	Std
Enclosed Cabin with split doors and Air-conditioning system.	Optional

HYDRAULIC SYSTEM	
Hydraulic Gear Service Pump	75 l/min
MAX load lifting speed	0,4 m/sec
MAX load lowering speed	0,4 m/sec

STANDARD MAST	
3300mm triplex with free lift	Std
FEM IIIB Carriage with load back rest	Std
Integrated Side-shift carriage with 1200mm long forks	Std
4th valve with hydraulic line on carriage	Std
Anti-cavitation valve on tilting control	Std
Mast front tilting angle	10°
Mast back tilting angle	12°

MISCELLANEOUS	
Fuel tank capacity	70 l
Hydraulic tank capacity	90 l
Electrical system voltage	12v

AVAILABLE OPTIONS	
Hydraulic Forks Positioner	Optional
Perkins Stage V engine	Optional
Spark arrestor in exhaust system	Optional
Approaching Blue Spot-light for pedestrian safety (front and rear)	Optional
Pedestrian Anti-Collision camera	Optional
Duplex Mast with or without free-lift (lifting heights from 2850mm to 4050mm available)	Optional
Triplex mast with free-lift different from standard (lifting heights from 3600mm to 7050mm available)	Optional
Agricultural, grass, Industrial or non-marking tyres	Optional