

Masted forklifts trucks

■ MA 460/470

- Capacity : 6000 kg and 7000 kg
- Lifting height : 4.00 m
- Engine : 106.5 hp
- 4 wheel drive
- Hydrostatic transmission
- Bucket capacity* : 1.20 m³

ARTICULATED CHASSIS



*Bucket and T.I. in option.

MA 460-470



Load capacity

MA 4606000 kg
 MA 4707000 kg
 at 600 mm load centre.



Lifting height :4.00 m

Lifting speed (m/s) :
 unladen/laden MA 460 :0.35/0.23
 MA 470 :0.32/0.30
 Lowering speed (m/s) :
 unladen/laden MA 460/MA 470 :0.37/0.43



Tyres

Front :18 x 22.5 XF Michelin
 Rear :18 x 22.5 XF Michelin



Forks (mm)

Length :1500
 Width x thickness :150 X 70



Brakeshydraulically operated



PERKINS engine1004.4 T

Bore and stroke :100x127
 Capacity :4 cyl. - 3990 cm³
 Rated speed :2300 r.p.m.
 Power (ISO/TR 14396) :78.5 kw (106.5 HP)
 Max.torque :349 Nm at 1800 r.p.m.
 Direct injection
 Water cooling



TransmissionHydrostatic

2 speed forward and reverse
 Travel speed :25 km/h
 Electromagnetic reversing shift



Hydraulics

Main pump (lifting/tilting) 1st :
 Gear type :200 bars /92 l/mn
 Steering pump
 Gear type :175 bars /92 l/mn



Capacities

Cooling system15 l.
 Engine oil11.5 l.
 Hydraulic oil144 l.
 Transmission oil3 l.
 Fuel tank121 l.



Weight (with forks) MA 4609200 kg
 MA 4709670 kg

Mast	Overall height mast lowered (mm)		Overall height mast extended (mm)	
	with kit	without kit	with kit	without kit
3.60 m	3235	3210	5035	5010
4.00 m	3435	3410	5435	5410
4.50 m	3685	3660	5935	5910

	MA 460	MA 470
Tipping load (frontal)	9114 kg	9935 kg
Draw bar pull (laden)	8200 daN	8200 daN

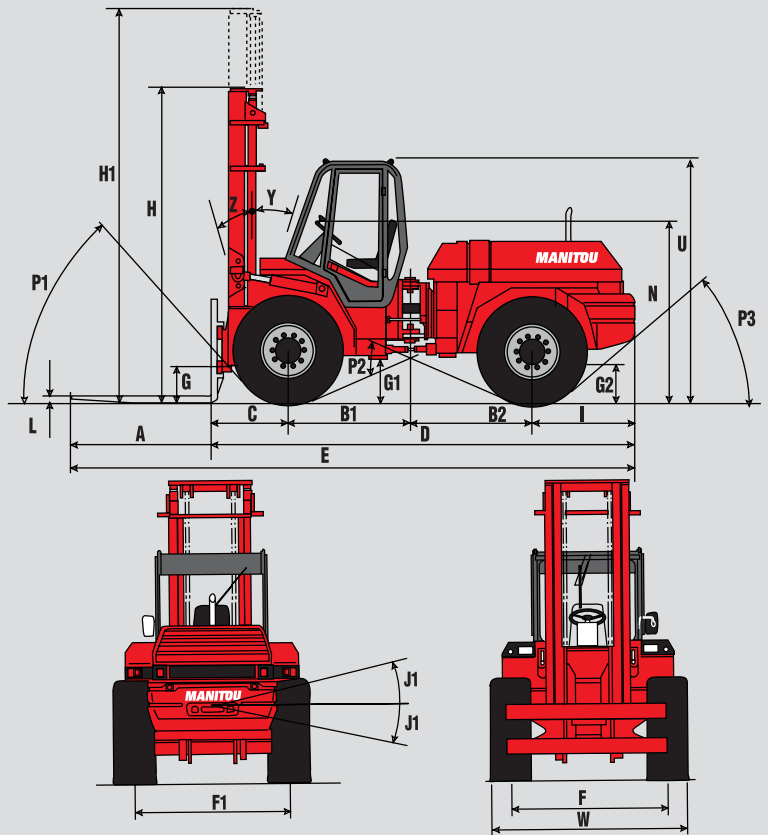

A	1500
B1	1300
B2	1300
C	817
D	4517
E	6017
F	1740
F1	1740
G	360
G1	480
G2	410
H	3410
H1	5410
I	1100
J	40°
J1	13°
K	1750
L	70
N	1960
O	150
P1	55°/122%
P2	48°/111%
P3	38°/78%
R	4415
S	7308
T	3272
U	2565
V	4990
V1	2430
W	2180
Y	12°
Z	17°

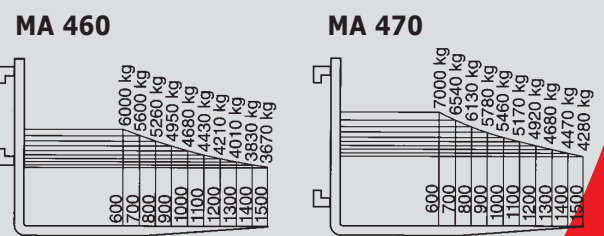
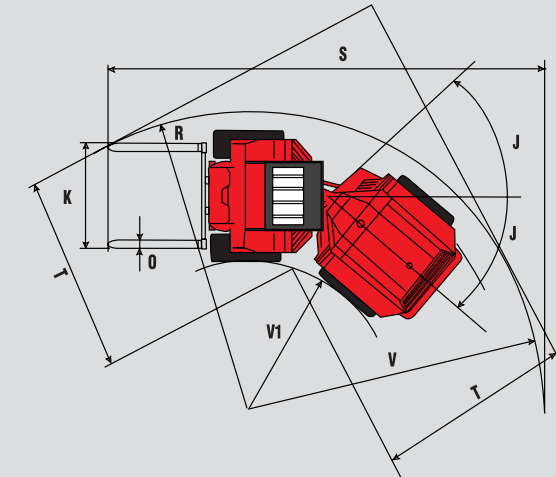

This publication in no way constitutes an offer and the company reserves the right to alter specification without prior notice.



MANITOU BF SA

B.P. 249 - 44158 Ancenis Cedex - France
 Tél. : 33 2 40 09 10 11 / Export Department Fax : 33 2 40 09 10 97
 www.manitou.com

700131EN - BI 004/Ind E

