

MANISCOPIC

MT 1340
SLT & SLT ULTRA





- Maximum lifting height : 13 m
- Capacity : 4000 kg
- Maximum forward reach : 9.35 m
- Torque convertor
- Hydraulic stabilizers
- Frame levelling

 **MANITOU**

MT 1340 SLT/SLT ULTRA

 **Lifting capacity** 4000 kg
at 500 mm from forks heels.
Tipping load at maximum reach1740 kg
Tear out force with bucket
to ISO 8313.....7000 daN

 **Lifting height** :13 m
Times : unladen / loaded (in s)
Lifting11.8/12.3
Lowering8.4/7.9
Simultaneous extension 1st and 2nd booms.....17/17
Simultaneous retraction 1st and 2nd booms...14/13.5
Time unladen (in s)
Crowd4.75
Dump.....4.20

 **Tyres**
440/80-24 T37 158B

 **Forks** (mm)
Length.....1200
Width x thickness.....125 X 50
Maximum distance between forks.....1040
Carriage rotation.....124°

 **Multidisc brakes - hydraulically assisted on both axes**

 **PERKINS Engine**
Type.....1104C.44 Turbo
Capacity..... 4 cylindres - 4400 cm³
Power (ISO/TR 14396) :100 HP/74.5 kw
at 2200 rpm
Maximum torque412 Nm at 1400 rpm
Direct Injection
Water Cooling

 **Transmission**Torque convertor
Electro-hydraulic reversing shift
4 speeds forward and reverse
Maximum travel speed.....25 km/h

 **Hydraulics**
Lifting/tilting pump
gear type.....260 bars/166 l/mn
Flow divider with priority to steering and brakes

 **Capacities**
Cooling system18.5 l.
Engine oil11 l.
Hydraulic oil126 l.
Transmission oil16 l.
Fuel tank135 l.

 **Weight unladen** (with forks)11180 kg
Overall width2.43 m
Overall height2.59 m
Turning radius (outside wheels)4.15 m
Overall length5.96 m
Ground clearance0.50 m
Drawbar pull.....9400 daN

Reach at maximum height : 1.79 m

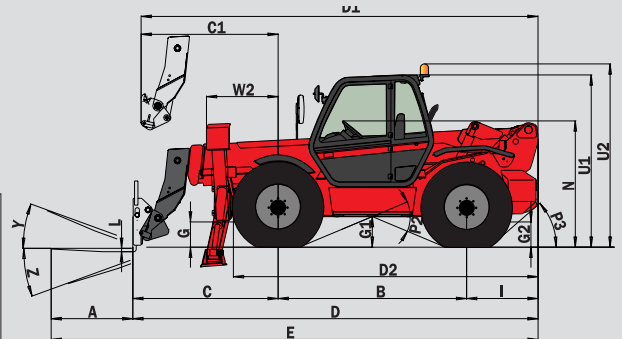
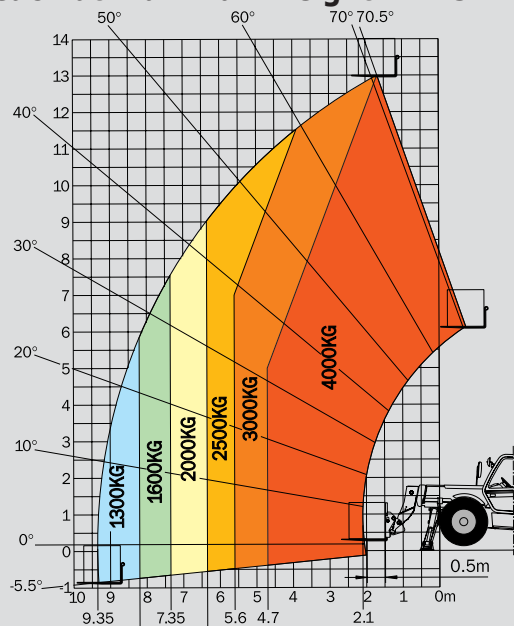

A	1200
B	2770
C	2135
C1	2045
D	5955
D1	5865
D2	4435
E	7155
F	1990
F1	1990
G	500
G1	495
G2	500
G3	290
H	7°
H1	7°
I	1050
J	950
K	1040
L	50
N	1880
O	125
P2	45.5°
P3	50°
R	3935
S	8870
T	4665
U1	2590
U2	2770
V	5750
V1	1470
V2	4150
W	2425
W1	3820
W2	1050
W3	2350
Y	12°
Z	112°

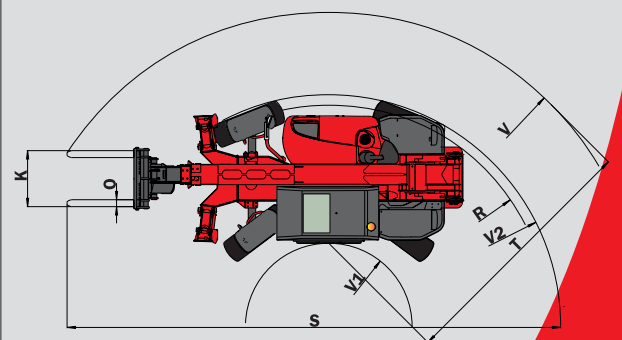
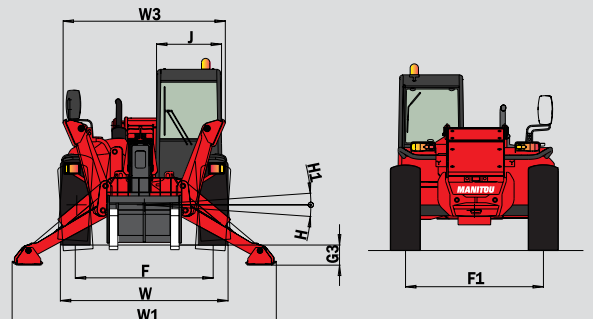

This publication in no way constitutes an offer and the company reserves the right to alter specification without prior notice.
The MANITOU models presented in this brochure can be supplied complete with optional equipment attachments.
PATENTS FR 93 14367 - EP 0 656 315 US PENDING

